

Laminate Flooring on Wall Installation Instructions

Vertical Wainscot Style

Although originally designed as a durable floor covering, many consumers have started using Quick-Step® laminate flooring on walls to give their rooms more character and to create a feature or accent wall.

Laminate can be utilized as a decorative covering over an existing clean, dry, secure and vertical wall that meets building codes. The wall substrate should be primed or painted drywall (gypsum board) only. Do not install directly over wallpaper or paneling. Laminate is not intended to be used on ceilings, countertops or as any type of structural material.

The installation wall should only run vertical to the floor. Sloping walls and surfaces that are parallel to the floor, such as ceilings or soffits, should not be selected. Limit installations to a maximum of 40 feet in length and a maximum of 1 plank length in height.

Laminate is suitable for an accent wall when used in climate controlled (35-65% RH and 60-85° F) indoor installations only. Acclimate unopened product lying flat in the room where it is to be installed for at least 48 hours. Mix planks from different cartons as you install to maximize the natural appearance.

Check wall for moisture, visible water stains or leaking windows. Do not install laminate over a wall with known moisture damage. Do not install in areas near water sources such as a backsplash over a sink or bathtub. Acceptable job site conditions, including relative humidity and wall moisture conditions, must be maintained throughout the life of the laminate application.

Check wall for flatness within 3/16" over 10 feet. Correct any unevenness before installing to allow the laminate planks to lie flat without rocking.

The following requirements are not intended to supersede federal, state or local building codes, but as with many other interior finish products, may require modifying existing structural components for successful installation. Owner assumes responsibility for compliance with all building codes including maintaining the required distance from heat sources such as fireplaces.

WARNING: For a safe and secure installation, this product **MUST** be installed in accordance with these installation instructions.

Tools Required for Installation:

- Caulk gun
- Utility knife
- Stud finder (electronic)
- Carpenters level or laser level
- Chalk line
- 18 gauge brad nail gun (electric or air)
- Tape measure
- Pencil
- Safety glasses
- Dust mask
- Gloves

Materials Required for Installation:

- 1-1/2" – 1-3/4" brad nails
- 100% silicone adhesive caulk (clear)

Other Tools and Materials:

- Hammer
- Uniclic® appropriate tapping block
- Pull bar
- Saw for cutting laminate planks
- Pry bar (for removing existing base or trim)
- Chair rail, wall base and quarter round moldings (to frame out accent wall)

Measure the length and width of the wall area to determine the total square footage area. Order that amount of flooring plus an additional 10% for incorrect cuts.

Remove all base and trim from accent wall. Measure from the floor a distance equal to your laminate plank plus one inch then level and mark the wall with a chalk line. With an electronic stud finder locate and mark wall studs. (Figure 1)

Turn off power while working around wall outlets and light switches. Pay special attention to avoid contact with electrical wiring.

Inspect each plank for damage before installing. (Figure 1a)
Do not install damaged planks. You can use laminate planks with or without an attached pad. There is no need to remove the pad, so treat the installation the same for both types of planks.

Start from the left side with the short side tongue up and long side groove toward the wall. Place one plank against the wall and align at the top to test fit. You will want a 1" gap at the bottom of the plank. (Figure 2a)

Determine the appropriate number of vertical planks to fill the wall. For the best appearance, the first and last planks should be approximately the same width. Cut them as needed based on the width of your installation and the width of your planks.

If you don't need to cut the first plank, remove lower extension of long side groove with saw or utility knife. (Figure 2b)

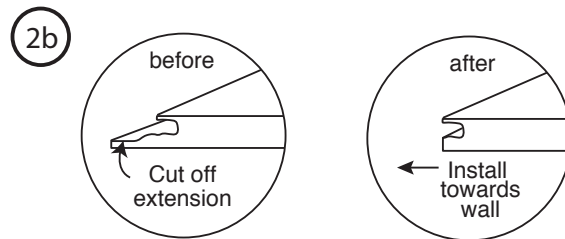
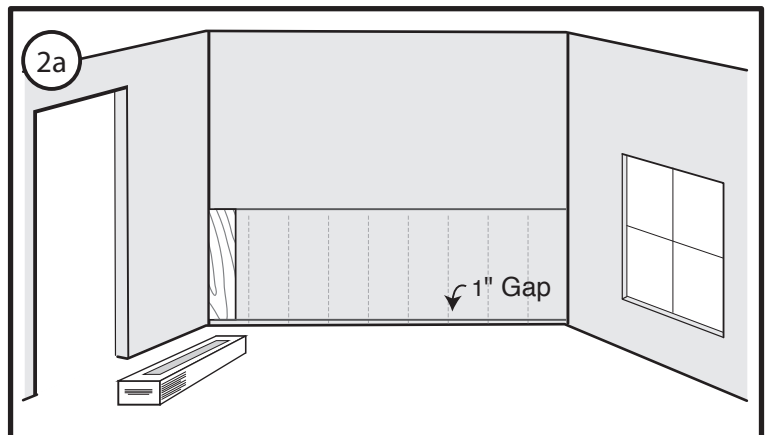
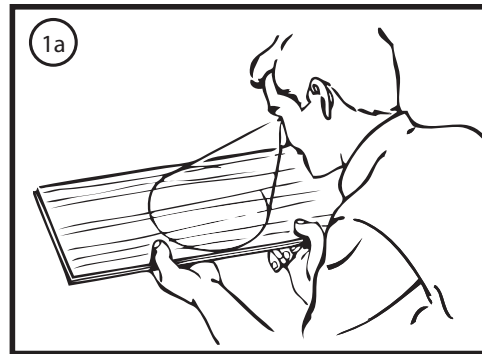
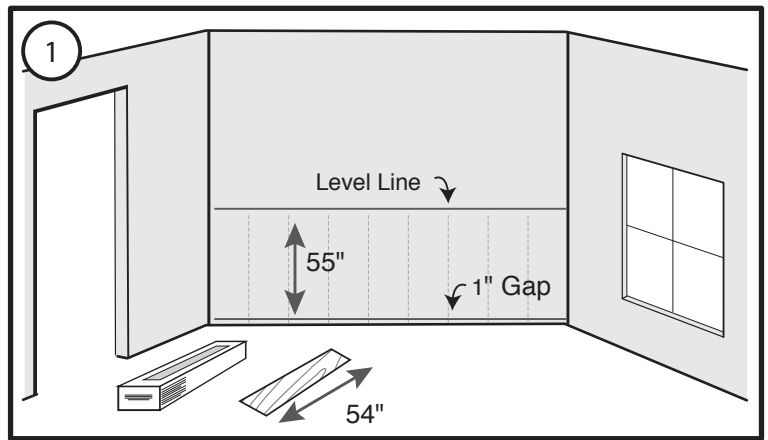

Apply silicone adhesive to the back side of the plank in an "S" pattern. If you're using a laminate plank with an attached pad, apply the silicone directly to the pad on the back of the plank. (Figure 3)

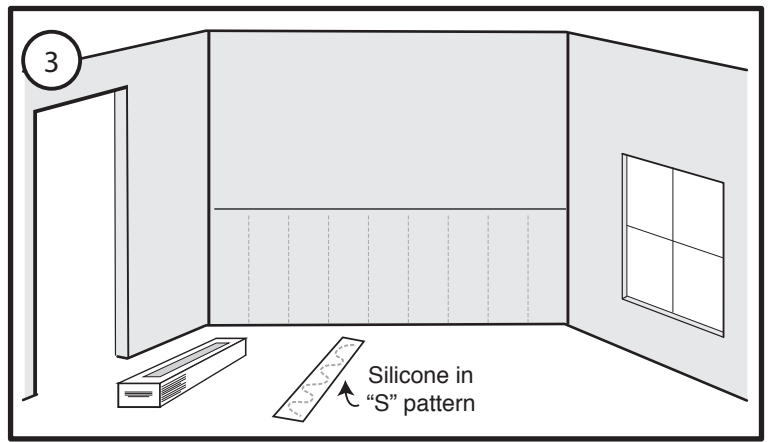

Adhere the plank to the wall leaving a 3/16" gap (A) from the corners of the wall and a 1" gap (B) at bottom. Drive brad nails 1/2" from the top and bottom of each plank to secure to wall. Place nails where the trim will cover.

Continue with the installation for each subsequent plank by first applying silicone adhesive to the back side of the plank in an "S" pattern. Then angle the groove over the tongue of the previous plank and wiggle into place. Tighten joints as needed with a tapping block or pull bar. Finally, drive brad nails 1/2" from the top and bottom of each plank to secure to wall. Place nails where the trim will cover. Be sure to drive the brad nails into a stud whenever possible. (Figure 4)

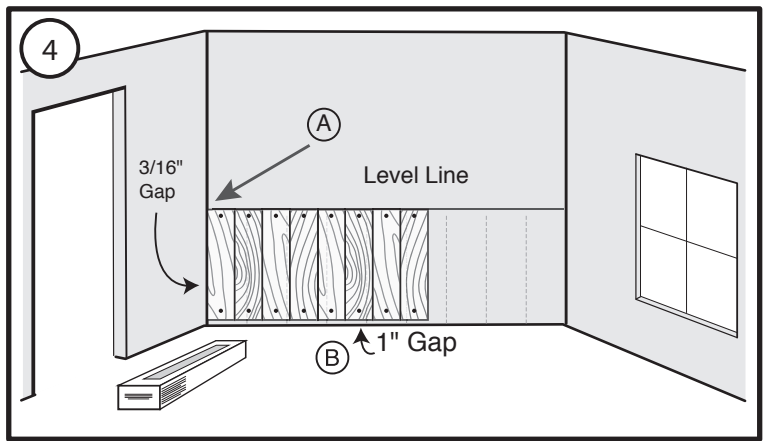

Finish wainscot accent to ending wall. (Figure 5)

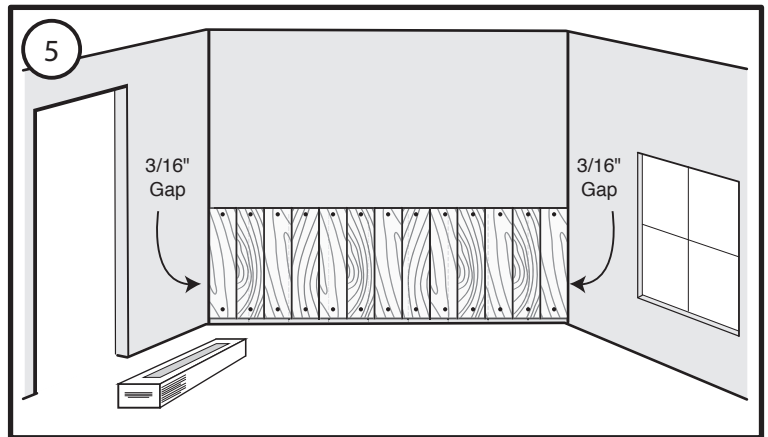

Install trim (chair rail) over the top edge. Install quarter round in the corners. Finish by installing the baseboard of your choice. (Figure 6)

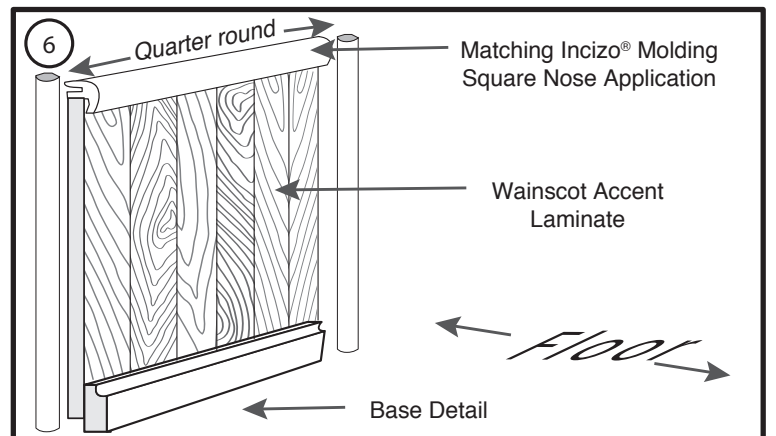

Care and Cleaning

Dry wipe as primary cleaning method. Occasionally damp wipe with water only. **NO wet washing.** If needed, use 1 cup of vinegar per gallon of water OR 1/3 cup non-sudsing ammonia per gallon of water. **DO NOT** use detergents, abrasive cleaners, soaps, waxes or polishes. Wipe off spills immediately. **DO NOT allow moisture to remain on the product surface for longer than 30 minutes.**

DO NOT attach objects such as pictures, shelves or television mounts directly to the laminate wall. **DO NOT** apply adhesive backed hooks or install screws or nails into the laminate wall for hanging objects. Instead, drill clearance holes through the laminate and mount these objects directly to wall studs with screws or nails. Drill the clearance holes through the laminate at least ¼" larger than the diameter of the fastener that will be used.

Precautionary Measures: Power tools should be equipped with a dust collector. If high dust level are encountered use an appropriate NIOSH designated dust mask. Avoid dust contact with skin and eyes. First Aid Measures in case of irritations: In case of irritation flush eyes and skin with water for at least 15 minutes.

ATTN: INSTALLERS Caution: Wood Dust

Sawing, sanding and machining wood products can produce wood dust. Airborne wood dust cause respiratory, skin and eye irritation. The International Agency for Research on Cancer (IARC) has classified wood dust as a nasal carcinogen in humans.

IMPORTANT HEALTH NOTICE FOR MINNESOTA RESIDENTS ONLY:

THESE BUILDING MATERIALS EMIT FORMALDEHYDE. EYE, NOSE, AND THROAT IRRITATION, HEADACHE NAUSEA AND A VARIETY OF ASTHMA-LIKE SYMPTOMS, INCLUDING SHORTNESS OF BREATH, HAVE BEEN REPORTED AS A RESULT OF FORMALDEHYDE EXPOSURE. ELDERLY PERSONS AND YOUNG CHILDREN, AS WELL AS ANYONE WITH A HISTORY OF ASTHMA, ALLERGIES, OR LUNG PROBLEMS, MAY BE AT GREATER RISK. RESEARCH IS CONTINUING ON THE POSSIBLE LONG-TERM EFFECTS OF EXPOSURE TO FORMALDEHYDE. REDUCED VENTILATION MAY ALLOW FORMALDEHYDE AND OTHER CONTAMINANTS TO ACCUMULATE IN THE INDOOR AIR. HIGH INDOOR TEMPERATURES AND HUMIDITY RAISE FORMALDEHYDE LEVELS. WHEN A HOME IS TO BE LOCATED IN AREAS SUBJECT TO EXTREME SUMMER TEMPERATURES, AN AIR-CONDITIONING SYSTEM CAN BE USED TO CONTROL INDOOR TEMPERATURE LEVELS. OTHER MEANS OF CONTROLLED MECHANICAL VENTILATION CAN BE USED TO REDUCE LEVELS OF FORMALDEHYDE AND OTHER INDOOR AIR CONTAMINANTS. IF YOU HAVE QUESTIONS REGARDING THE HEALTH EFFECTS OF FORMALDEHYDE, CONSULT YOUR DOCTOR OR CALL LOCAL HEALTH DEPARTMENTS.

Limited Warranty For Wall Installations Only

Quick-Step® Limited Lifetime* Residential Warranty

Quick-Step® provides the following limited lifetime* residential warranty to the original purchaser for as long as he or she owns the product in its original installation: (1) the laminate surface will not fade due to sun or electrical light; and (2) the laminate surface will not stain. These limited warranties are subject to the conditions described in the "Conditions" section below.

Quick-Step® Limited 6-Month Manufacturing Warranty

Quick-Step® provides a limited warranty to the original purchaser for six (6) months from the date of purchase covering any manufacturing defects in the product.

The Quick-Step® Limited 6-Month Manufacturing Warranty is made subject to the following condition:

This limited warranty does not cover any damage that occurs during shipment or installation.

All areas must be assessed prior to installation to determine if other surface measures need to be taken or conditions addressed, including, but not limited to requirements for static control, state health and building codes, high impact use and moisture/water exposure. Other than the specific warranty identified above, Quick-Step® provides no additional warranties and Quick-Step® does not warrant that any of the uses identified above are in compliance with any applicable building, health, inspection, and/or other municipal regulation or codes. Quick-Step® is not responsible for usage that is not in compliance with any regulation or code. Proper assessment of location and usage must be applied. Contact your Quick-Step® representative for questions on performance in specific locations.

The Quick-Step® Limited Lifetime* Residential Warranty is made subject to the following conditions:

- 1) The product must be installed properly in accordance with Quick-Step® laminate wall installation instructions.
- 2) The product must be used only indoors in a dry, climate-controlled area.
- 3) These limited warranties apply to vertical wall installations only. They do not apply to floor installations.
- 4) Other horizontal uses of this product are not covered by these limited warranties. Never install this product on a ceiling or as a countertop.
- 5) The product must be maintained in accordance with Quick-Step® laminate care and maintenance instructions.
- 6) Damage must not have occurred as a result of improper or inadequate maintenance or accidents, such as damage caused by scratching, impact or cutting.
- 7) Gloss or sheen change and variations from later product additions or non-warranty repairs are not covered by these limited warranties.
- 8) These limited warranties do not apply to water damage, including but not limited to water damage caused by flooding, standing water, leaking pipes, mechanical failures, appliance leaks or pet urine. Do not use this product as a backsplash or otherwise install near sinks or other wet work areas.
- 9) These limited warranties do not apply to damage caused by water or moisture in the wall or behind the product, including but not limited to damage from hydrostatic pressure (water or moisture on the wall behind the product that is transmitted to the surface through exerted pressure) or other conditions that result in water or moisture being behind the product.
- 10) These limited warranties do not apply to moldings.
- 11) Installation of product that contains any manufacturing defect is not covered by these limited warranties.
- 12) These warranties do not apply to any product installed in a commercial application.

* The warranty period is pro rata 33 years. A pro rata warranty is one that provides for a refund or credit that decreases according to a set formula as the warranty period progresses. The original warranty value is reduced by the amount of time that you own it. When a claim is made, the value of the warranty becomes a percentage of ownership based upon 33 years. Any services provided as part of this warranty do not extend the original warranty period.

How to Make Claims:

Any claim under any of the limited warranties above must be made by contacting your retailer within 30 days after the basis for the claim is detected. In addition, any claim under any of the limited warranties above must be made before the end of the applicable limited warranty period. Proof of purchase, including the date of purchase, must be presented to make a claim.

Quick-Step®'s Responsibility:

If Quick-Step® accepts a claim under any of the limited warranties above, Quick-Step® will repair or replace, at its option, the affected Quick-Step® product material only. Labor costs for removal and/or installation or repair associated with a warranty claim are not covered. If Quick-Step® in its sole discretion determines that such repair or replacement is not reasonably achievable, Quick-Step® may choose to refund the purchase price of the affected Quick-Step® material. If the design for which a claim is made is no longer available, Quick-Step® will replace the affected product materials with another Quick-Step® design of equal or greater value at Quick-Step®'s discretion. Upon approval of the warranty claim, Quick-Step® will provide you with instructions on the manner in which to proceed in order to have your material repaired or replaced, and you must comply with such instructions within ninety (90) days after the claim is approved or your rights under the limited warranty will be deemed waived. The above remedies are the sole and exclusive remedies for claims on this product. These limited warranties give you specific legal rights, and you may also have other rights which vary from State to State.

DISCLAIMERS:

QUICK-STEP® DISCLAIMS ALL OTHER EXPRESS OR IMPLIED WARRANTIES, INCLUDING ANY IMPLIED WARRANTY OF MERCHANTABILITY OR FITNESS FOR A PARTICULAR PURPOSE, WITH RESPECT TO THIS PRODUCT.

Quick-Step® disclaims liability for incidental and consequential damages. Some States do not allow the exclusion or limitation of incidental or consequential damages, so the above limitation or exclusion may not apply to you.

These limited warranties are not transferable. They extend only to the original end-consumer.

Samples, descriptions, and other information concerning the product contained in Quick-Step® catalogs, advertisements, or other promotional material or statements made by sales representatives or distributors are for general informational purposes only and are not binding upon Quick-Step®. No sales representatives or distributors shall have any authority whatsoever to establish, expand or otherwise modify Quick-Step®'s warranties.

The provisions of these limited warranties are deemed to be severable and the invalidity or unenforceability of one provision shall not affect the validity or enforceability of any other provision. These limited warranties constitute the entire agreement of the parties, and no waiver or amendment shall be valid unless in writing and signed by an authorized representative of Quick-Step®.

Care and Cleaning

Dry wipe as primary cleaning method. Occasionally damp wipe with water only. **NO wet washing.** If needed, use 1 cup of vinegar per gallon of water OR 1/3 cup non-sudsing ammonia per gallon of water. **DO NOT** use detergents, abrasive cleaners, soaps, waxes or polishes. Wipe off spills immediately. **DO NOT allow moisture to remain on the product surface for longer than 30 minutes.**